

LS 25B 2 adjustable throughbeam photoelectric sensor for detection through foils

en 01-2016/11 50135277

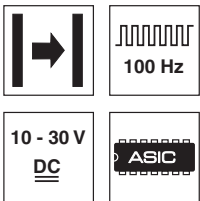

200m

- Throughbeam photoelectric sensor with infrared light source
- Extremely high performance reserve
- Small and compact construction with robust plastic housing, protection class IP 66/IP 67 for industrial application
- High-precision adjustment by potentiometer on transmitter and receiver
- PNP or NPN switching outputs
- Further options for adapting to the respective application
- Snap-locking connector for time-saving installation

Dimensioned drawing

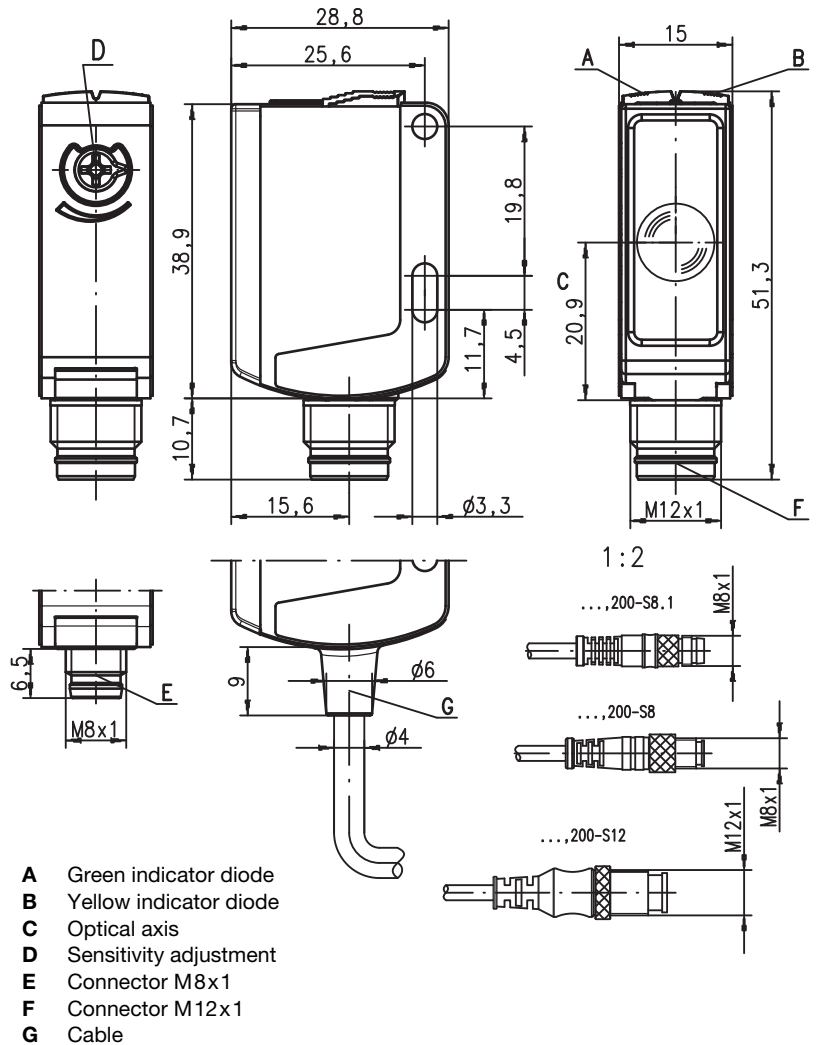

- A** Green indicator diode
- B** Yellow indicator diode
- C** Optical axis
- D** Sensitivity adjustment
- E** Connector M8x1
- F** Connector M12x1
- G** Cable

Electrical connection

Transmitter:

Receiver:

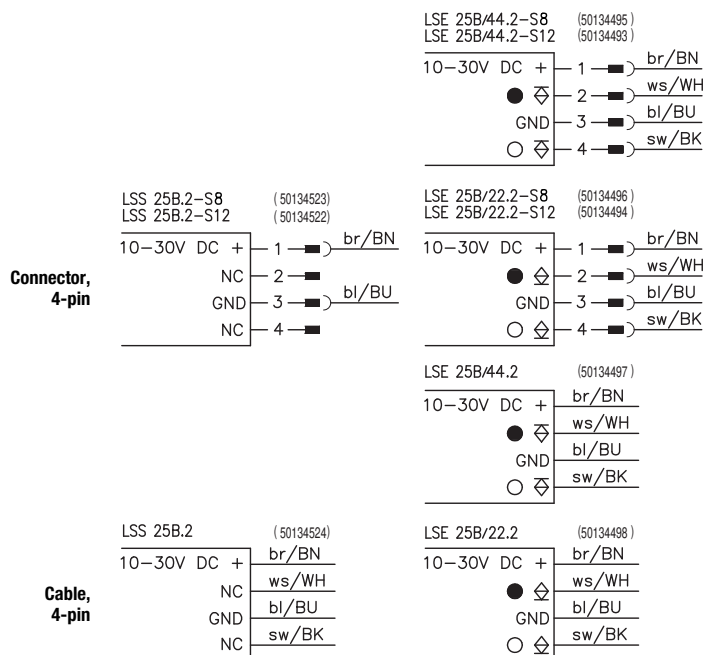

We reserve the right to make changes • DS_LS25B_2_en_50135277.fm



Accessories:

(available separately)

- Mounting systems (BT 25, UMS 25...)
- Cable with M8 or M12 connector (K-D ...)
- Alignment aid (SAT 5)

Specifications

Optical data

Typ. operating range limit ¹⁾	240m
Operating range ²⁾	200m
Light source ³⁾	LED (modulated light)
Wavelength	850nm (infrared light)

Timing

Switching frequency	100Hz
Response time	5ms
Delay before start-up	≤ 300ms

Electrical data

Operating voltage U_B ⁴⁾	10 ... 30VDC (incl. residual ripple)
Residual ripple	≤ 15% of U_B
Open-circuit current	≤ 20mA
Switching output	.../44... 2 PNP switching outputs pin 2: PNP dark switching pin 4: PNP light switching
	.../22... 2 NPN switching outputs pin 2: NPN dark switching pin 4: NPN light switching
Function characteristics	light/dark switching
Signal voltage high/low	≥ ($U_B - 2V$)/≤ 2V
Output current	max. 100mA
Operating range	adjustable with potentiometer on transmitter and receiver

Indicators

Green LED	ready
Yellow LED	light path free

Mechanical data

Housing	plastic (PC-ABS)
Optics cover	plastic (PMMA)
Weight	with connector: 15g with 2m cable: 55g
Connection type	cable 2m (cross section 4x0.21mm ²), M8 or M12 connector



Environmental data

Ambient temp. (operation/storage) ⁵⁾	-40°C ... +55°C/-40°C ... +60°C
Protective circuit ⁶⁾	2, 3
VDE safety class ⁷⁾	II
Protection class	IP 66, IP 67
Light source	free group (in accordance with EN 62471)
Standards applied	IEC 60947-5-2
Certifications	UL 508, C22.2 No.14-13 ^{4) 5) 8)}

- 1) Typ. operating range limit: max. attainable range without performance reserve
- 2) Operating range: recommended range with performance reserve
- 3) Average life expectancy 100,000h at an ambient temperature of 25°C
- 4) For UL applications: for use in class 2 circuits according to NEC only
- 5) UL certified in the temperature range -30°C to 60°C
- 6) 2=polarity reversal protection, 3=short-circuit protection for all transistor outputs
- 7) Rating voltage 50V
- 8) These proximity switches shall be used with UL Listed Cable assemblies rated 30V, 0.5A min, in the field installation, or equivalent (categories: CYJV/CYJV7 or PVVA/PVVA7)

Tables

0	200	240
---	-----	-----

	Operating range [m]
	Typ. operating range limit [m]

Diagrams

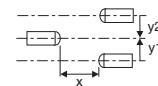
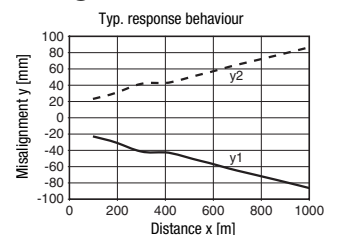

The diagram shows the typical distance range for detection through foils up to 1000mm. Please contact us for operating ranges larger than 1000mm.

Remarks

Operate in accordance with intended use!

- ⚠ This product is not a safety sensor and is not intended as personnel protection.
- ⚠ The product may only be put into operation by competent persons.
- ⚠ Only use the product in accordance with the intended use.

A light axis consists of a transmitter and a receiver with the following designations:

LS	= complete light axis
LSS	= transmitter
LSE	= receiver

UL REQUIREMENTS

Enclosure Type Rating: Type 1

For Use in NFPA 79 Applications only.

Adapters providing field wiring means are available from the manufacturer. Refer to manufacturers information.

CAUTION – the use of controls or adjustments or performance of procedures other than those specified herein may result in hazardous radiation exposure.

ATTENTION ! Si d'autres dispositifs d'alignement que ceux préconisés ici sont utilisés ou s'il est procédé autrement qu'indiqué, cela peut entraîner une exposition à des rayonnements et un danger pour les personnes.

LS 25B 2 adjustable throughbeam photoelectric sensor for detection through foils

Order guide

The sensors listed here are preferred types; current information at www.leuze.com.

Throughbeam photoelectric sensor for detection through foils with high performance reserve and sensitivity adjustment with potentiometer		Designation	Part no.	
Transmitter	With 4-pin M8 connector	LSS 25B.2-S8	50134523	
	With 4-pin M12 connector	LSS 25B.2-S12	50134522	
	With cable, cable length 2m	LSS 25B.2	50134524	
Receiver	With 4-pin M8 connector	Pin 4 PNP light switching, Pin 2 PNP dark switching	LSE 25B/44.2-S8	50134495
		Pin 4 NPN light switching, Pin 2 NPN dark switching	LSE 25B/22.2-S8	50134496
	With 4-pin M12 connector	Pin 4 PNP light switching, Pin 2 PNP dark switching	LSE 25B/44.2-S12	50134493
		Pin 4 NPN light switching, Pin 2 NPN dark switching	LSE 25B/22.2-S12	50134494
	With cable, cable length 2m	Pin 4 PNP light switching, Pin 2 PNP dark switching	LSE 25B/44.2	50134497
		Pin 4 NPN light switching, Pin 2 NPN dark switching	LSE 25B/22.2	50134498

Any combinations of the transmitters and receivers listed here are possible.

Adjusting the throughbeam photoelectric sensor LS 25B...2...

	MOUNTING RECOMMENDATION
↻ Mount the transmitter on the more accessible side.	

Adjustment for transparent foils

- ↻ Set the potentiometer at the receiver at the center ("six o'clock")
- ↻ Position a multi-folded foil in front of the transmitter (fold four to six times)
- ↻ Turn the transmitter potentiometer counter-clockwise to the MIN position ("one o'clock").
- ↻ The yellow LED on the receiver must be OFF.
If not, turn the receiver potentiometer a little counterclockwise.
- ↻ Turn the transmitter potentiometer clockwise until yellow LED on receiver turns ON.
- ↻ Move the foil stack. Yellow LED on the receiver must remain ON.
- ↻ Hold showfinger in front of the foil stack. This must lead to the switching of the yellow receiver LED.

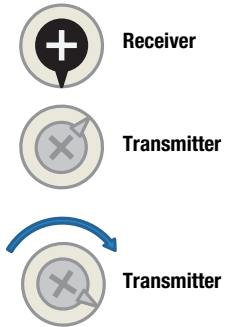

Adjustment for opaque foils

- ↻ Turn the potentiometer on the receiver to the MAX position ("eleven o'clock")
- ↻ Position a multi-folded foil in front of the transmitter (fold two to four times)
- ↻ Turn the transmitter potentiometer counter-clockwise to the MIN position ("one o'clock"). The yellow LED on the receiver must be OFF.
- ↻ Turn the transmitter potentiometer clockwise until yellow LED on receiver turns ON.
- ↻ Move the foil stack. Yellow LED on the receiver must remain ON.
- ↻ Hold showfinger in front of the foil stack. This must lead to the switching of the yellow receiver LED.

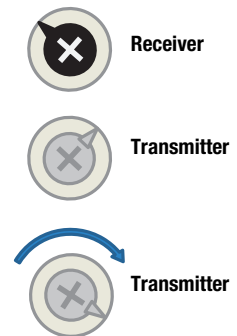

	NOTICE
In case of reflections on metallic glossy machine parts the reduction of the transmission power at the transmitter potentiometer is preferable to reducing the sensitivity on the receiver side.	